

THE POWER OF

REDARC[®]

GoBlock

PORTABLE DUAL BATTERY SYSTEM

MODELS:

- PPS12050
- PPS12100

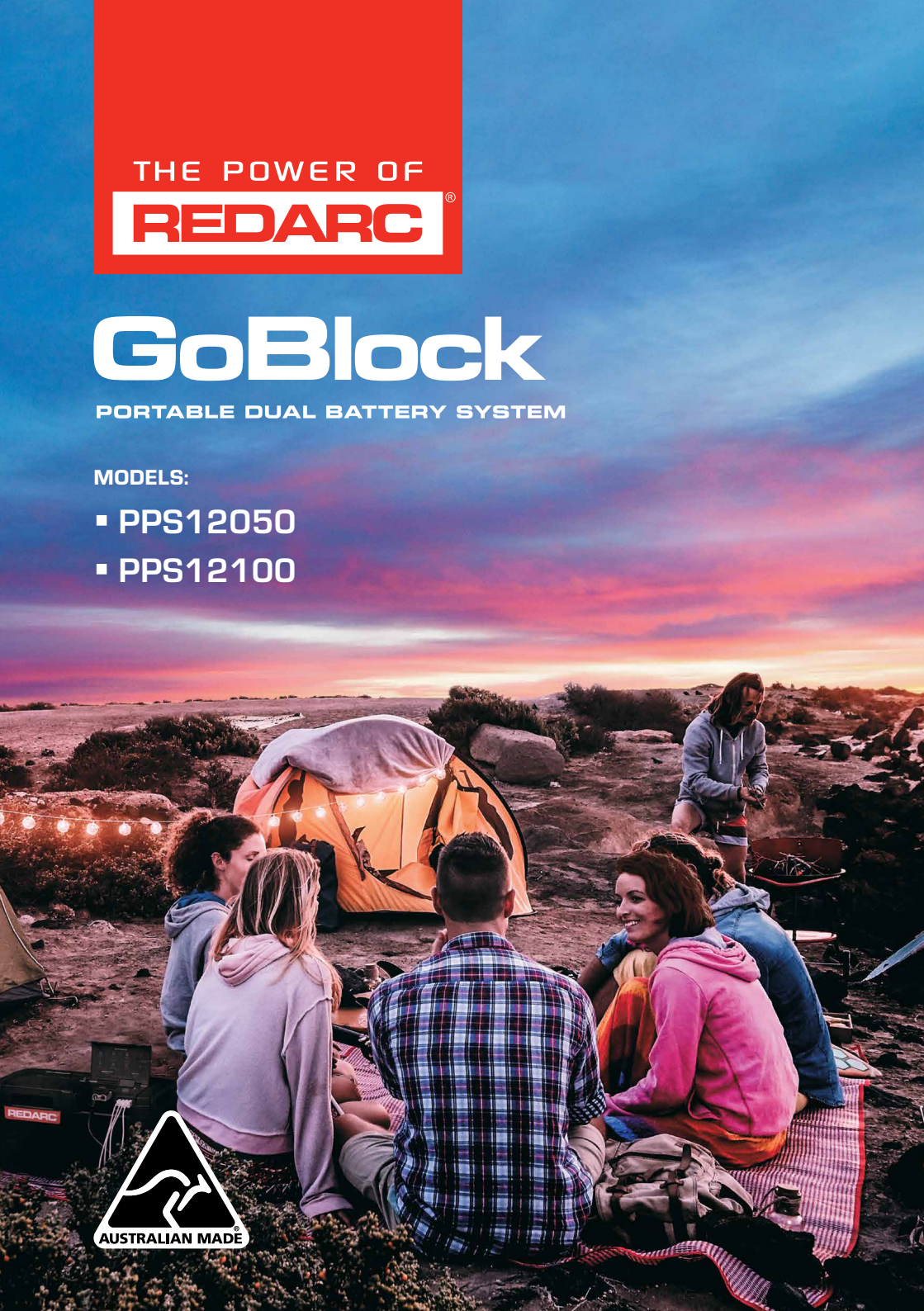



GoBlock

PORTABLE DUAL BATTERY SYSTEM

Not all portable power is created equal. Only one system was designed, engineered, built and tested to handle the most unforgiving conditions on earth — the Australian Outback.

The GoBlock[®] is a fully contained Portable Dual Battery System that also functions as a Portable Power Station, and can be used without any installation.

GoBlock[®] features output sockets for charging common camping and outdoor products and mobile electronics devices, and also connects to the free RedVision[®] App for maximum freedom and control.

THE POWER OF

REDARC[®]

CONTENTS

WARNINGS & SAFETY INFORMATION	4	TRANSPORTING THE GoBlock	29
QUICK START	6	Carry Handles	29
GoBlock PARTS	8	Safe Vehicle Transportation	30
GoBlock CONTROLS AND LEDS	10	CARE AND MAINTENANCE	32
Control Button LED	10	Care and Maintenance Advice	32
Battery Level LEDs	11	Long-Term Storage	33
TURN GoBlock ON AND OFF	12	INVERTERS	34
CHARGE THE GoBlock	13	TROUBLESHOOTING	35
Charge From an AC Outlet	13	Faults	35
Charge From a Vehicle Accessory Socket ..	14	Alerts	35
Charge Directly Via a Vehicle Alternator ..	15	General Troubleshooting	38
Charge From the PowerDock	16	TECHNICAL SPECIFICATIONS	40
Charge From Solar Panels/Blankets	17	WARRANTY	43
Green Power Priority	18	ADDITIONAL INFORMATION	44
SOLAR PANELS	19	Safe Disposal of the Product	44
Portable Solar Panels	19	GoBlock Shipping Advice	44
Solar Panels via the PowerDock	20	Checking the Product Serial Number	44
START-BATTERY RECOVERY MODE	21		
Recovery (Dock)	21		
Recovery (Aux)	22		
REDARC RedVision® APP	24		
Pair to the GoBlock Via Bluetooth	24		
Controlling the GoBlock Remotely	26		
Change the Vehicle DC Input Threshold ..	27		
Recovery Via the RedVision® App	28		

WARNINGS & SAFETY INFORMATION

Save these instructions — this manual contains important safety instructions.

Do not operate the system unless you have read and understood this manual.

REDARC recommends that the PowerDock referenced in this manual be installed by a suitably qualified person (*PowerDock not included*).

Disclaimer: REDARC accepts no liability for any injury, loss or property damage which may occur from the improper or unsafe installation or use of its products.

⚠ WARNING

- An unsecured GoBlock can become dangerous in an accident or sudden stop. The GoBlock must be adequately restrained for safe transportation in a vehicle ([page 30](#)). Choose appropriate load restraint equipment, and ensure it's in good working order before every use.
- Keep clear of naked flame, sparks or conductive material while charging/discharging the GoBlock.
- Do not attempt to alter or disassemble the GoBlock under any circumstances. Incorrect handling or reassembly may result in a risk of electric shock, fire or explosion. Any attempt to disassemble the unit, make unapproved repairs or modifications will void the warranty and the user's authority to operate the GoBlock. All faulty units must be returned to REDARC for repair.
- Do not attempt to charge non-rechargeable batteries, as an explosion may result.
- Do not insert foreign objects or fingers into the input/output sockets.
- Do not expose the battery to temperatures beyond the published limits.
- Do not incinerate or dispose of in fire.
- Do not crush or puncture the battery.
- Do not submerge the battery in liquid — GoBlock is NOT waterproof.
- Do not operate the battery beyond the published ratings. Doing so may result in damage to the battery, fire, explosion and ultimately burns. For this reason, it is of utmost importance that you follow the instructions when installing and using the GoBlock.
- The GoBlock has a rugged design that can withstand significant forces, however if the GoBlock main housings should become damaged heavily (cracked or broken), discontinue use of the unit immediately.

⚠ CAUTION

- The Battery should not be used by persons (including children) with reduced physical, sensory or mental capabilities, or lack of experience and knowledge, unless they are supervised or have been instructed on how to use the appliance by a person responsible for their safety. Children should be supervised to ensure that they do not play with the GoBlock.
- Cable and fuse sizes are specified by various codes and standards which depend on the type of vehicle the GoBlock is installed into. Selecting the wrong cable or fuse size could result in harm to the installer or user and/or damage to the Battery or other equipment installed in the system. The installer is responsible for ensuring that the correct cable and fuse sizes are used when installing the GoBlock PowerDock. Refer to the installation instructions supplied with the REDARC PowerDock for detailed information.

NOTICE

- Keep the GoBlock away from major heat sources, high voltage, and avoid exposure to sunlight for long periods of time.
- REDARC recommends only using genuine Anderson™ connectors for GoBlock installations. Counterfeit or generic connectors may result in a poor quality connection.

SAFETY MESSAGE CONVENTIONS

Safety messages in this manual include a signal word to indicate the level of the hazard as follows:

⚠ WARNING

A potentially hazardous situation which, if not avoided, **could result in death or serious injury to the operator or to bystanders.**

⚠ CAUTION

A potentially hazardous situation which, if not avoided, **may result in moderate or minor injury to the operator or to bystanders.**

NOTICE

A situation that **will not cause personal injury but may cause equipment damage.**

QUICK START



Before you begin, make sure the GoBlock firmware is up-to-date.

Download and install the RedVision® App on your smartphone and connect it to your GoBlock (see [page 24](#)).

The app will automatically detect if there is a new firmware version available — simply follow the in-app prompts to install the new firmware.

REDARC recommends disconnecting from all inputs and outputs before commencing a firmware update.

GET THE APP...

GET THE RedVision® APP



Download the free REDARC RedVision® App to connect the GoBlock to your smartphone via Bluetooth®. Scan the QR code or search for 'REDARC' on your device's app store.

Use the app to control and monitor your GoBlock remotely, and get access to in-app features, the latest GoBlock firmware and help. More on [page 24](#).

The RedVision® App and its interactions with the GoBlock have not been tested on all smartphone models. Visit the application pages within each App store to view compatibility details.



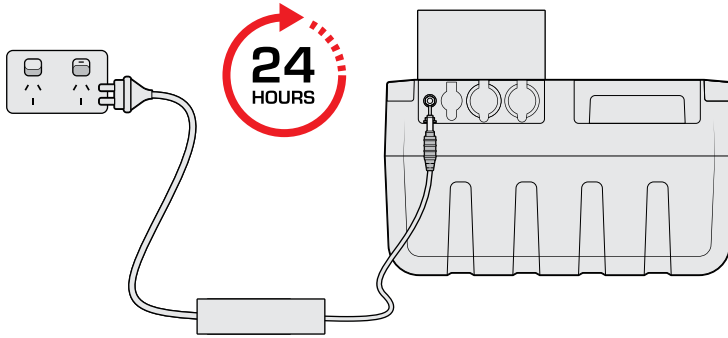

Charge for 24 hours

The GoBlock is supplied partially charged. To get the best out of your GoBlock, fully charging it before the first-use is recommended. This will allow the internal cells to equalise and ensure optimum life-cycle and performance of your GoBlock.

Connect the GoBlock to a powered wall outlet using the 7.5 A Mains Trickle-Charger. Charge for approximately 24 hours. See [page 13](#) for more ways to charge your GoBlock.

...CHARGE...

...GO

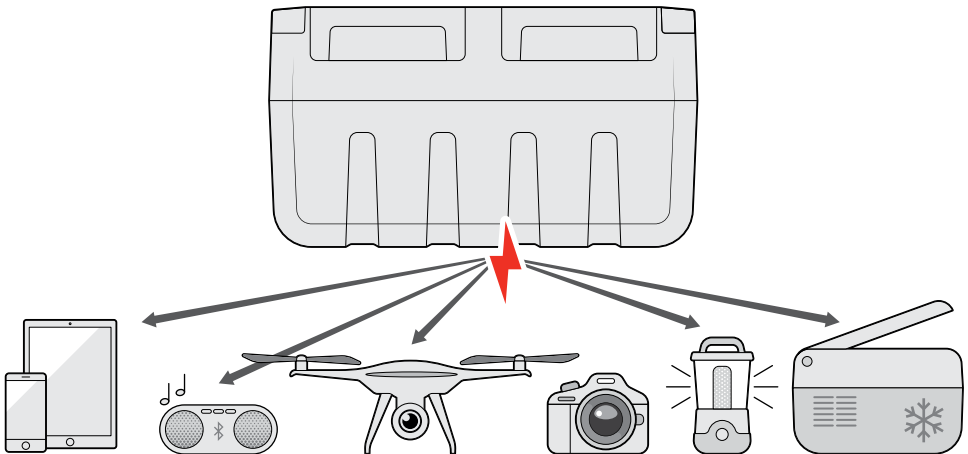

GoBlock PARTS

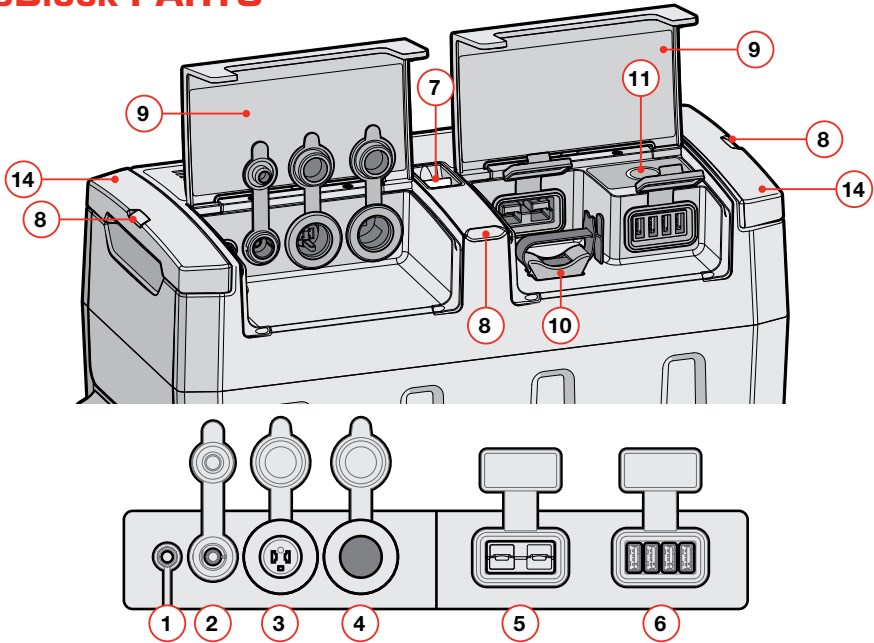

1. Trickle-Charge Input

Input socket for charging the GoBlock battery from either the supplied 7.5 A Mains Trickle-Charger (page 13) or the 7.5 A Accessory Socket Trickle-Charger (page 14).

2. Merit Socket

Connect devices with a Merit connector (15 A maximum).

3. Fridge Socket

Connection point for a portable fridge (15 A maximum).

4. Accessory Socket

Connect devices with an automotive Accessory connector (cigarette lighter type) (10 A maximum).

5. 50 A Anderson™ Output

Connect devices with an Anderson™ connector (50 A maximum). Connect an inverter (max. 700 W) for powering AC devices such as laptops.

6. USB Type A (× 4)

Four USB Type A ports (2.4 A each).

7. PowerDock Anchor Point

The PowerDock connects securely onto the Anchor Point when the GoBlock is docked and locked.

8. Restraint Strap Guides (× 4)

Indented guides to assist with the positioning of tie-down straps for safe transportation (page 30).

9. Protective Covers

Prevents dust and light water spray from entering the input/output sockets.

10. Cable Strain Relief

Protects the Anderson™ Output connector from strain or accidental disconnection (page 32).

11. Control Button

A Multi-function button that turns the GoBlock On and Off (page 12), turns the Battery Level LEDs On, and Initiates Recovery Mode (Dock and Aux) (page 21).

The Control Button illuminates in different colours to display GoBlock operational information (page 10).

NOTE: The total output capability of the GoBlock is 50 A. If the total draw of loads connected to the outputs exceeds 50 A then the listed maximum rating of each output may not be achieved.

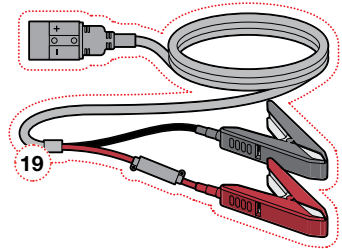
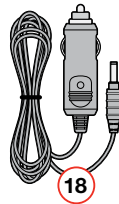
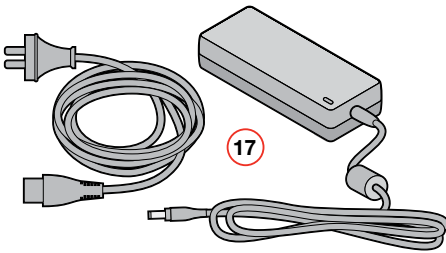
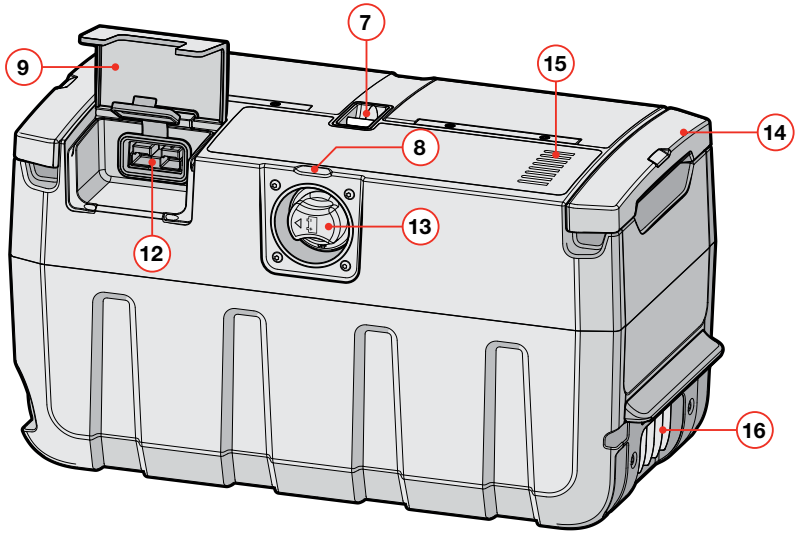

12. Auxiliary Anderson™ Input (50 A)

Connection interface for Auxiliary input including solar panels (page 17) and Battery Recovery Leads/Clips (not included) for the Recovery function (page 22)

Charge your GoBlock directly from a vehicle alternator (page 14) (cable not included).

13. Storage Isolation Switch

Isolates the GoBlock's internal battery for prolonged periods of storage (or prior to shipping) (page 33).

14. Carry Handles

The extendable Carry Handles are a comfortable and safe way to carry the GoBlock (page 29).

15. Battery Level LEDs

Displays the charge level of the internal battery during charging/discharging (page 11).

Displays Alert Codes for the identification of Alerts (page 35).

16. PowerDock Interface

Connection interface for the REDARC PowerDock (not included, available for separate purchase).

17. 7.5 A Mains Trickle-Charger

Charges the GoBlock from an AC wall outlet via the Trickle-Charge Input (page 13).

18. 7.5 A Accessory Socket Trickle-Charger

Charges the GoBlock from a vehicle accessory socket via the Trickle-Charge Input (page 14).

19. Battery Recovery Leads (not included)

Connect a flat auxiliary battery to the GoBlock Auxiliary Anderson™ Input for the Recovery function (page 22).

GoBlock CONTROLS AND LEDS

Provided that the GoBlock has adequate charge, the Battery Level LEDs will display the GoBlock's charge level for 30 seconds by doing one of the following:

- Press the Control Button.
- Plug devices/chargers into the GoBlock input/output sockets.
- Open the RedVision® App (page 24) that has been previously paired to the GoBlock.

NOTE: if the GoBlock does not give any LED indications, check that the Storage Isolation Switch (page 33) is turned 'ON' before trying again.

Control Button LED

The Control button provides an interface for you to power On/Off the GoBlock, access and initiate Recovery Modes, and operate Bluetooth® functions. It has an LED that illuminates in white, blue, green, yellow, and red to indicate the status of each GoBlock function.

NOTE: when the GoBlock is in App Control Mode, the Control Button menu is disabled and all GoBlock functions must be controlled via the App.

A Control Button LED reference label is located on the underside of the adjacent Protective Cover.



Turn GoBlock On/Off (press and hold) (page 12)



Bluetooth® Pairing Mode (page 24)



App Control Mode (page 24)



Recovery Mode (Dock) (page 21)



Recovery In Progress (Dock)



Recovery Mode (Aux) (page 22)



Recovery In Progress (Aux)



Alert (page 35)



Fault (page 35)

Battery Level LEDs

The primary function of the Battery Level LEDs is to display the battery level during both charging and discharging, however it also displays the following information:

- Alert Codes to notify the user in the event of an Alert (page 35).
- The progress of the Recovery (Dock) and Recovery (Aux) Modes (page 21).
- Displays the Power Off count-down when turning the GoBlock off (page 12).

Note that the Battery Level LEDs always fill from bottom to top consecutively when displaying the battery charge level. If the Battery Level LEDs display a non-consecutive LED pattern, this is indicative of an Alert or Recovery progress.



Battery charge remaining
Displays the amount of charge remaining in the GoBlock.



Battery charging progress
Each segment will flash while it is charging.

LOW BATTERY

When the battery level is low (less than 5% charge remaining), the GoBlock will operate normally. There will be an alarm tone that will repeat each time the charge level reduces by a further 1%.

When the battery level is critically low (less than 3% charge remaining), the Control button will flash red, and the GoBlock will disable outputs and will go to sleep. The GoBlock will automatically power off when the battery level reaches 0%.

TURN GoBlock ON AND OFF

GoBlock features an automatic Sleep Mode to save power, and will wake up automatically when a load or input is detected.

GoBlock can also be turned Off via the Control Button. This disables Bluetooth® and disconnects all input/output sockets so that loads plugged into the GoBlock do not draw power.

NOTE: the Storage Isolation Switch does NOT turn the GoBlock Off — loads may still be powered via the output sockets if there is any input source.

Do not use the Storage Isolation Switch to turn the GoBlock on/off during normal use. Instead, turn the unit on/off via the Control Button.

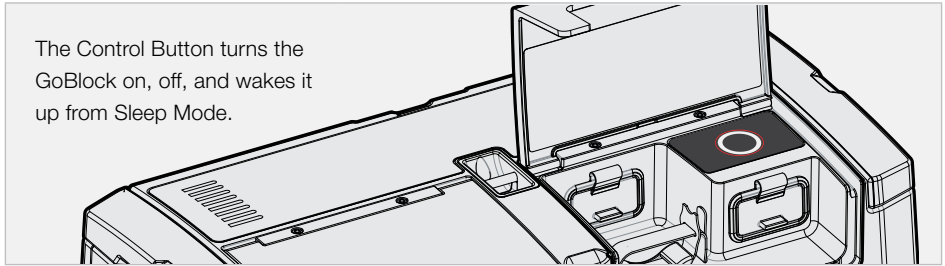

Turn the GoBlock On

Make sure the Storage Isolation Switch is turned 'ON'. See '[Storage Isolation Switch](#)' (page 33).

Press the Control Button once to turn the GoBlock On. GoBlock will beep once and the Battery Level LEDs will illuminate.

Turn the GoBlock Off

Make sure the Control Button LED is either solid blue or off, then Press and hold the Control Button for approximately 5 seconds or longer. After a further 3 seconds the Control Button LED will illuminate white and the Battery Level LEDs will begin to count down. The Battery Level LEDs will count down from top to bottom. Continue pressing the button until there are three beeps — all outputs and the Auxiliary Anderson input are now Off.

The count-down can be cancelled at any time by releasing the Control Button.



The Control Button LED is solid white during the Power Off count-down (press and hold).

CHARGE THE GoBlock

GoBlock contains a high-quality lithium iron phosphate battery (LiFePO₄) battery that is capable of a rapid 50 A recharge rate.

The GoBlock is supplied partially charged, however charging the battery fully before its first use is recommended. This is in order to equalise the internal battery cells for optimum battery cycle-life, and to ensure that the Battery Level LEDs are as accurate as possible.

The GoBlock does not need to be completely flat before charging and can be topped up at any time.

⚠ CAUTION

- When recharging the GoBlock internal battery at the full 50 A rate, or when the total input/output load current is ≈ 50 A, the top housing around the inputs/outputs may become hot — take care when handling.
- When recharging the GoBlock internal battery, ensure that there is airflow around the unit to prevent it from overheating — do not charge in direct sunlight/hot area as the charging performance may be affected.
- Only use the supplied AC Charger (Mains Trickle-Charger) to charge the GoBlock.

The GoBlock has the following charging options:

- 7.5 A AC Mains Trickle-Charger (240 VAC) (*supplied*)
- 7.5 A DC Accessory Socket Trickle-Charger (*supplied*)
- Up to 50 A Anderson™ input from solar panels (*solar panels sold separately*)
- 50 A Anderson™ input using vehicle power (*Anderson™ cable required, sold separately*)
- 50 A DC vehicle power via the PowerDock (*dock sold separately*)
- Up to 50 A DC fixed solar panels via the PowerDock (*dock and solar panels sold separately*)

Charge From an AC Outlet

Plug the supplied 7.5 A Mains Trickle-Charger into a powered AC outlet, then plug the charger into the Trickle-Charge Input on the GoBlock.

Charging from an AC wall outlet.

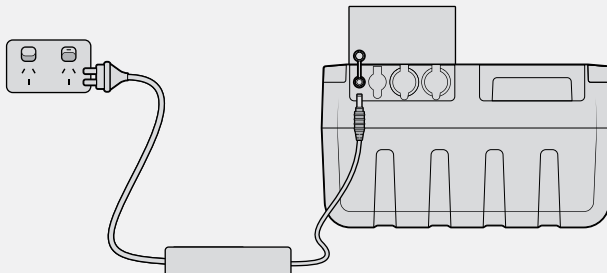

Charge From a Vehicle Accessory Socket

Plug the supplied 7.5 A Accessory Socket Trickle-Charger into a vehicle accessory socket in your vehicle, then plug the charger into the Trickle-Charge Input on the GoBlock.

The GoBlock will charge at a maximum rate of 7.5 A, however this may be less depending on the voltage of the vehicle.

IMPORTANT: when charging via the 7.5 A Accessory Socket Trickle-Charger, the **GoBlock may completely discharge your vehicle battery** in the following cases:

- If the vehicle accessory socket is connected directly to the vehicle start battery; i.e. the socket is powered even when the vehicle ignition is off)
- When the ignition is in the 'ACC' position; e.g. listening to music while the engine is not running.

Ideally, only charge via the vehicle accessory socket when the engine is running.

⚠ CAUTION

- When charging the GoBlock from a vehicle accessory socket, ensure that the Trickle-Charger accessory connector is fully inserted into the accessory socket in the vehicle. Poor contact can cause the plug to overheat.
- The Accessory Socket and Trickle-Charger connector may become hot during normal use — take care when handling.

Charging from a vehicle accessory socket using the Trickle-Charger.

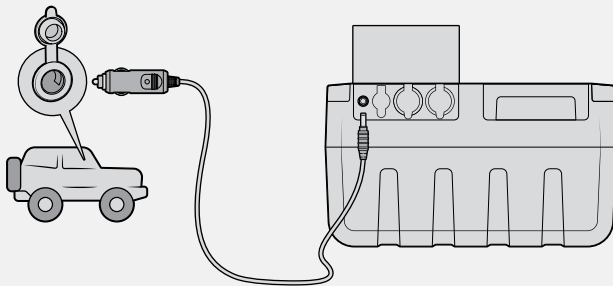

Charge Directly Via a Vehicle Alternator

Connect directly to your vehicles alternator via an extension cable (not included) to the Auxiliary Anderson™ Input on the back of the GoBlock. Use a suitable adaptor if the power output connector on you vehicle is not an Anderson™ connector.

Visit the REDARC website for detailed instructions on how to run a direct wire from your start battery to charge via the Auxiliary Anderson Input.

The extension cable positive wire must be fused to 60 A. Refer to the 'Cable Sizing' table to select an appropriate cable gauge for your installation.

If your vehicle has a Variable-Voltage or Smart Alternator, you may need to change the 'DC Vehicle Input Threshold' setting via the RedVision App in order for GoBlock to charge correctly. For more information, see 'Change the Vehicle DC Input Threshold' (page 27).

NOTICE

- REDARC recommends only using genuine Anderson™ connectors manufactured by Anderson Power Products® for GoBlock installations. Counterfeit or generic connectors may result in a poor quality connection.

Charging from a vehicle alternator via an Anderson™ cable.

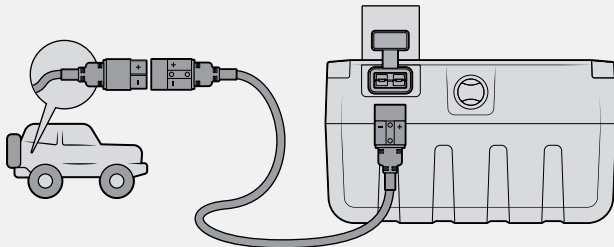

CABLE SIZING

Purchase cable length and gauge to suit your individual installation. 'Cable Install Length' refers to the total cable length of the install (i.e. the total length of the cables from the vehicle battery positive terminal to the PowerDock grounding point). Always choose a cable cross sectional area equal-to or greater-than the size specified in the table. The selected cable must be capable of carrying a minimum of 60 A.

Cable Install Length		Recommended Wire Cross Section	Closest Equivalent (BAE, B&S, AWG)
1 – 5 m	3' – 16'	≥ 13.56 mm ²	6
5 – 9 m	16' – 30'	≥ 20.28 mm ²	4

Charge From the PowerDock

NOTE: PowerDock is sold separately.

Depending on the PowerDock installation configuration, GoBlock will automatically charge simultaneously via the PowerDock from the following sources:

- Fixed solar panels (e.g. vehicle-mounted solar panels) (1)
- Vehicle power (2)

The charging sources will be automatically selected based on the priority defined by the Green Power Priority feature [\(page 17\)](#).

If your vehicle has a Variable-Voltage or Smart Alternator, you may need to change the 'DC Vehicle Input Threshold' setting via the RedVision App in order for GoBlock to charge correctly. For more information, see '[Change the Vehicle DC Input Threshold](#)' [\(page 27\)](#).

Charging from an installed PowerDock.

NOTE: installation configurations may vary.

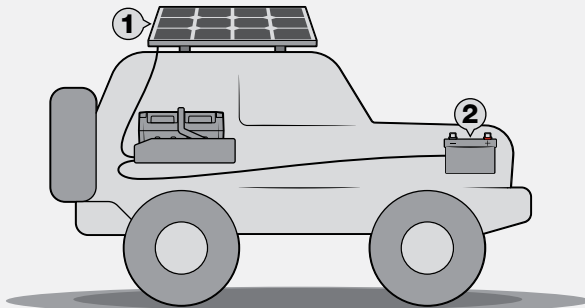

Charge From Solar Panels/Blankets

⚠ CAUTION

The maximum total output voltage of solar panels connected to the GoBlock must not exceed 32 V. Excessive voltage (> 32 V) from solar panels may damage the GoBlock internal electronics and could cause the unit to become hot. If overheating or smoke is detected, immediately disconnect the solar panels.

NOTICE

- Do not connect solar panels to the 50 A Anderson™ Output on the front of the GoBlock, as this may damage the unit. ONLY connect solar panels to the Auxiliary Anderson™ Input on the back of the GoBlock.
- Do not connect solar panels that have an in-built solar regulator, as it can interfere with the performance of the GoBlock's internal solar regulator.

Plug the solar panel's Anderson™ connector into the Auxiliary Anderson™ Input on the back of the GoBlock. An adaptor cable will be required if the panel does not have an Anderson™ type connector.

If using portable/folding solar panels or a solar blanket, position the panels to directly face the sun. This will ensure that maximum solar energy is collected.

For detailed information about using solar panels with your GoBlock, see [page 19](#).

Charging from 12 V portable solar panels (or blanket).

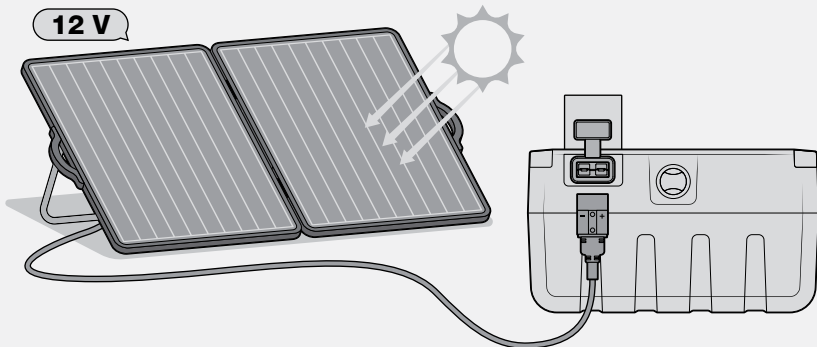

Green Power Priority

Green Power Priority is an automatic function that defines the order that input sources are prioritised. This ensures that the GoBlock will always take as much power as possible from solar panels before supplementing from other sources. This lightens the load on your vehicle alternator and maximises the collection of free solar energy.

Charging source priority is given in the following order:

1. Solar
2. AC Mains power
3. DC Vehicle power (via the vehicle's alternator while the vehicle is running)

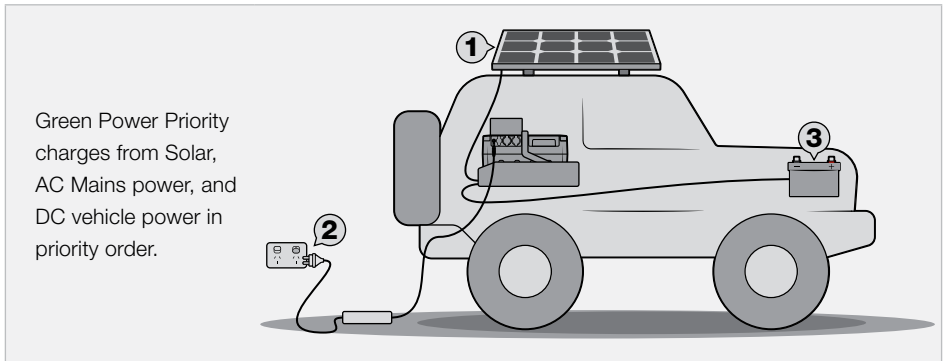

SOLAR PANELS

The GoBlock can be connected to Solar Panels in two ways:

- By directly connecting a solar panel to the Auxiliary Anderson™ Input on the GoBlock. See 'Charge From Solar Panels/Blankets' on page 17 for safety information.
- When docked in the PowerDock (*sold separately*) that has solar panels hard-wired to it.

GoBlock utilises intelligent Green Power Priority technology (page 17) in order to collect maximum solar energy from your solar panels.

Portable Solar Panels

Portable solar panels and solar blankets can be connected directly to the GoBlock via the Auxiliary Anderson™ Input.

NOTICE

Do not connect solar panels that have an in-built solar regulator, as it can interfere with the performance of the GoBlock's internal solar regulator.

1. Check if the solar panel has an Anderson™ connector — if not, use a suitable adaptor (not supplied).
2. Make sure the panels are free of dust and dirt— if not, wipe gently. Take care when cleaning to avoid scratching the panels, as scratches may reduce the performance of the panels.
3. Connect the Anderson™ connector on the solar panel to the Auxiliary Anderson™ Input on the back of the GoBlock — DO NOT connect it to the Anderson Output on the front.
4. Position the solar panel to directly face the sun, making sure that the panel is not partially shaded. If the panel cannot be positioned to directly face the sun, it can be oriented to face the equator at an angle of 45 degrees.
5. The GoBlock will automatically begin charging if there is adequate solar energy available, i.e., if it is sunny enough.

Solar Panels via the PowerDock

Solar panels can be hard-wired to the GoBlock PowerDock solar output. This allows the GoBlock to automatically charge from solar panels when docked.

For detailed information, refer to the installation instructions supplied with the PowerDock.

REDARC Solar Products

NOTICE

All accessory cables used with your GoBlock solar charging set-up must be adequately rated (i.e. a suitable diameter) to support the maximum short-circuit current rating of your solar panel.

REDARC Recommends the following REDARC solar products for charging your GoBlock.

Visit the REDARC website to view the full range of REDARC solar products.

Solar Panels

- REDARC 190 W solar blanket (SSF1190)
- REDARC 200 W monocrystalline portable folding solar panel (SPFP1200)
- REDARC 180 W monocrystalline fixed solar panel (SMSP1180)

Extension Cables

- 10 m (32') Anderson-to-Anderson™ extension cable (SRC0019)
- 5 m (16') Anderson-to-Anderson™ extension cable (SRC0018)

START-BATTERY RECOVERY MODE

In the event of a flat vehicle start battery, the GoBlock Recovery feature enables you to sacrifice some GoBlock charge and safely return it to the flat vehicle start battery.

This process can be initiated when the GoBlock is docked in the PowerDock, or by connecting the GoBlock Auxiliary Anderson™ Input to a vehicle start battery using Battery Recovery Leads (not supplied).

Once Recovery is initiated, GoBlock will charge the flat vehicle battery for approximately 15 minutes to transfer enough charge to safely start the vehicle. The 15 minute profile is designed to recover and perform maintenance on the flat vehicle start battery, providing a much better outcome than a standard jump-start.

Recovery (Dock)

Recovery can be initiated in two ways:

- via the Control Button
- via the REDARC RedVision® App — see '[Recovery Via the RedVision® App](#)' (page 28).

RECOVERY (DOCK) VIA THE CONTROL BUTTON

1. Enter Recovery Mode (Dock) by pressing the Control Button until it flashes green.
2. To initiate the Recovery process, press the Control Button for more than one second. The Control Button LED will illuminate solid green to indicate that Recovery is in progress.



Flashing green: Recovery (Dock) is ready to initiate.

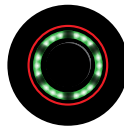

Solid green: Recovery (Dock) is in progress.

3. Progress will be displayed by the Battery Level LEDs. The green Battery Level LEDs will illuminate at a rate of approximately one LED every three minutes over a 15 minute period.
4. When Recovery is complete, the four green Battery Level LEDs will flash and an audio tune will play. This will continue for approximately three minutes, or until a vehicle input is detected.



The green Battery Level LEDs illuminate in sequence to indicate the Recovery (Dock) progress.



All green Battery Level LEDs are flashing — Recovery is ready.

Recovery (Aux)

Recovery can be initiated in two ways:

- via the Control Button
- via the REDARC RedVision® App — see 'Recovery Via the RedVision® App' (page 28).

Connecting the GoBlock to a flat vehicle start battery using REDARC GoBlock Battery Recovery Leads (not supplied).

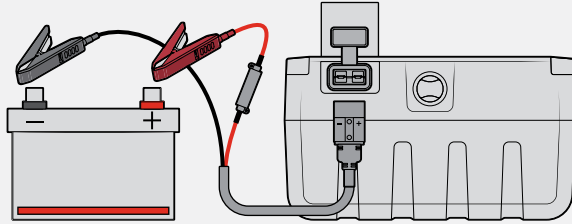

NOTICE

- Only connect the Recovery Leads to the Auxiliary Anderson™ Input on the back of the GoBlock. Do not connect the leads to the 50 A Anderson™ Output on the front of the GoBlock, as this may damage the unit.
- Ensure that the Recovery Lead clips are connected to the correct battery terminals. DO NOT connect them backwards.

RECOVERY (AUX) VIA THE CONTROL BUTTON

1. Plug the Anderson™ connector on the Battery Recovery Leads (not supplied) into the Auxiliary Anderson™ Input on the back of the GoBlock.
2. Connect the Battery Recovery Lead clips to the vehicle start battery. Connect the black clip to the negative (-) terminal, then connect the red clip to the positive (+) terminal.
3. Enter Recovery Mode (Aux) by pressing the Control Button until it flashes yellow.
4. To initiate the Recovery process, press the Control Button for more than one second. The Control Button LED will illuminate solid yellow to indicate that Recovery is in progress.



Flashing yellow: Recovery (Aux) is ready to initiate.



Solid yellow: Recovery (Aux) is in progress.

5. Progress will be displayed by the Battery Level LEDs. The green Battery Level LEDs will illuminate at a rate of approximately one LED every three minutes over a 15 minute period.
6. When Recovery is complete, the top yellow and all four green Battery Level LEDs will flash and an audio tune will play. This will continue for approximately three minutes, or until a vehicle input is detected.



The top yellow LED and the green Battery Level LEDs illuminate in sequence to indicate the Recovery (Aux) progress.



The top yellow LED and all green Battery Level LEDs are flashing – Recovery (Aux) is ready.

REDARC RedVision® APP

The RedVision® App is a component of the REDARC RedVision® ecosystem. A range of REDARC products (including GoBlock) are compatible with the RedVision® App (iOS and Android), and can be paired via Bluetooth® to your smartphone simultaneously.

The RedVision® App gives you remote access to the following GoBlock functions and features:

- Battery level monitoring
- System and input source monitoring
- Set the Vehicle DC Input Threshold (page 27)
- Recovery initiation (page 28)
- System diagnostics
- GoBlock firmware updates



GET THE RedVision® APP

Download the free REDARC RedVision® App to connect the GoBlock to your smartphone via Bluetooth®. Scan the QR code or search for 'REDARC' on your device's app store.

The RedVision® App and its interactions with the GoBlock have not been tested on all smartphone models. Visit the application pages within each App store to view compatibility details.

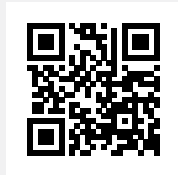

Pair to the GoBlock Via Bluetooth

1. Download and Install the RedVision® App.
2. Enable Bluetooth® on your smartphone.
3. Open the RedVision® App, then read and agree to any messages when prompted. Note, some smartphones will require Location Services to be enabled before the RedVision® App can connect to the GoBlock via Bluetooth.
4. Wake-up the GoBlock by pressing the Control Button. The Battery Level LEDs will turn on. If the GoBlock will not power on, check that the Storage Isolation Switch (page 33) is turned 'ON'.
5. Enter Bluetooth® pairing mode — press-and-hold the Control Button until the Control Button LED begins to flash blue, then release the button.

6. The Control Button LED will continue to flash blue while the GoBlock attempts to connect to nearby devices. When a successful connection is made, the Control Button LED will turn solid blue. Bluetooth® pairing mode turns off automatically after 90 seconds if no connection is made.



Blue flashing: Bluetooth®
Pairing Mode

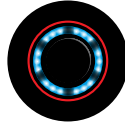

Blue solid: App Control Mode
(Bluetooth® connected)

If your smartphone will not connect to the GoBlock, follow the steps listed in '[GoBlock will not connect to the RedVision® App](#)' on page 39.

SUBSEQUENT CONNECTIONS

Once a smartphone has been paired with a GoBlock, it will automatically reconnect when the RedVision® App is opened and the GoBlock is selected from the list of available REDARC products.

PAIRING GoBlock TO MULTIPLE SMARTPHONES

The GoBlock can be paired to multiple smartphones, however it can only be monitored/controlled by one smartphone at a time. When the RedVision® App is minimised on one smartphone, the RedVision® App can be opened on another smartphone and will connect automatically if it has previously been paired.

To pair another smartphone, repeat the steps in '[Pair to the GoBlock Via Bluetooth](#)' (page 24).

DELETE ALL PAIRINGS

1. Enter Bluetooth® pairing mode — press and hold the Control Button on the GoBlock until the Control Button LED begin to flash blue, then release the button.
2. Press and hold the Control Button for four seconds or longer. The Battery Level LEDs will illuminate in order from bottom to top. Continue pressing the button until all LEDs (Control Button and Battery Level LEDs) flash rapidly 10 times. All pairings have now been deleted.

Controlling the GoBlock Remotely

NOTE: there may be some functional and visual differences in the RedVision® App to what is shown in this manual. Check the app store for the latest version of the RedVision® App.

Opening the RedVision® App will automatically wake-up the GoBlock, provided it has previously been paired successfully. Closing the app disconnects the smartphone from the GoBlock.

If there are multiple REDARC RedVision® products paired to your smartphone, switch between which product is connected to your smartphone by tapping on the Menu icon on the top left of the app. All available paired REDARC products will be listed — select the GoBlock you wish to control.

The RedVision® App Home Screen

Menu
Access settings, firmware updates, select/view a list of connected RedVision® compatible products.

Bluetooth connection status

Active device

Battery State of Charge

GoBlock State of Charge Widget
Displays active input sources, battery State of Charge and Charge/Discharge time forecasts.

Time to Full (if charging)

Time to Flat (if discharging)

Vehicle Input via the PowerDock

Solar Input via Dock or Auxiliary Input

Trickle Charge Input

Current Flow Widget
Displays the current flow into and out of the GoBlock.

Input Source Widget
Displays the percentage contribution of total supplied power from input sources along with the voltage of that source.

Loads

The screenshot shows a smartphone interface with a dark background. At the top, there is a status bar with the time 4:23, a Bluetooth icon, a signal strength icon, and a battery icon. Below the status bar is a power button icon. The main content area is divided into several sections. The top section is the 'GoBlock State of Charge Widget', which shows a battery icon with a green level indicator, the text '76%', and a forecast of '16 hrs' with an upward arrow. Below this is the 'Current Flow Widget', which shows a car icon with '7.9A' and a downward arrow, a battery icon with '7.3A' and an upward arrow, and a lightbulb icon with '1.0A' and a downward arrow. The bottom section is the 'Input Source Widget', which shows three input sources: a car icon, a solar icon, and a trickle charge icon, each with a horizontal bar representing its percentage contribution and the voltage '14.3V'.

Change the Vehicle DC Input Threshold

GoBlock is designed to charge from a vehicle input only when the vehicle is running and the alternator/battery voltage is high enough. This is to retain as much charge as possible in the vehicle start battery.

The default Vehicle Input Threshold is 12.7V, below which the GoBlock will stop charging. For vehicles with Variable Voltage or Smart Alternators, the alternator/battery voltage varies while running and can sometimes drop below 12.7V. This will result in the GoBlock not charging even though the vehicle is running. In these instances the Vehicle DC Input Threshold voltage can be changed using the RedVision App.

1. Connect the RedVision App to your GoBlock — tap on the Menu icon at the top left of the app to select/confirm that your GoBlock is selected from the Devices list.
2. Tap 'Product Settings' in the Menu.
3. Select and then confirm the DC Input Threshold setting that best suits your vehicle configuration.

AVAILABLE SETTINGS:

Standard Alternator (12.7V) – (Default) Suitable for most vehicles fitted with traditional type alternators.

Smart Alternator (12.4V) – The Recommended setting for safe automatic charging for vehicles with Smart Alternators.

Ignition Switched (12.0V) – For installations that have an ignition controlled relay that disconnects power to the GoBlock when ignition is OFF.

NOTE: when the Vehicle DC Input Threshold is set to 'Ignition Switched (12.0V)', you must use the wiring configuration shown on [page 28](#) or you will flatten your battery to 12 V.

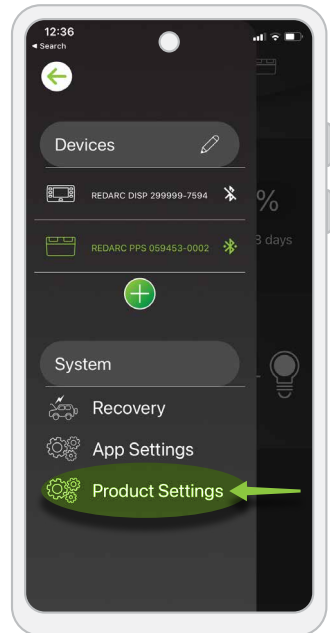

12.0V DC INPUT THRESHOLD WIRING

When the Vehicle DC Input Threshold is set to 'Ignition Switched (12.0V)' (page 27), you must use this wiring configuration **or you will flatten your battery to 12 V.**

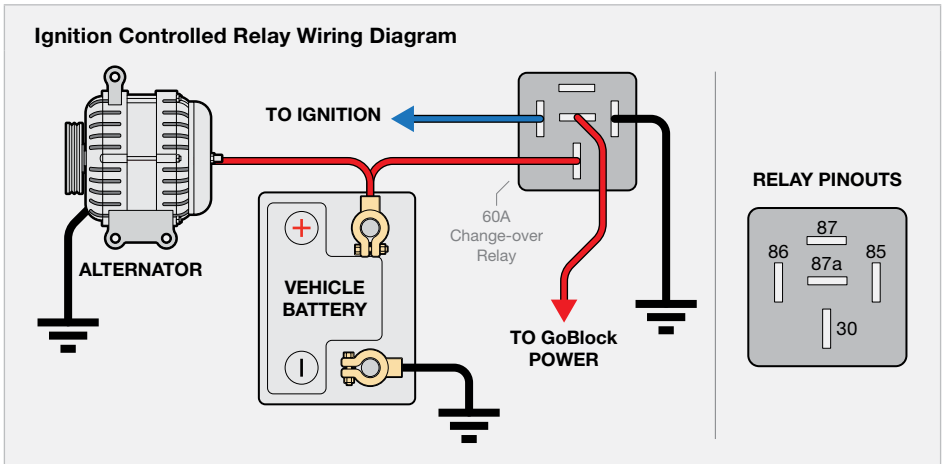

Recovery Via the RedVision® App

For detailed information about the Recovery function, see 'Start-Battery Recovery Mode' (page 21).

Recovery can be initiated in two ways — via the REDARC RedVision® App (steps below), or via the Control Button on the GoBlock, or. For steps to initiate Recovery via the Control Button, see 'Recovery (Dock)' (page 21) or 'Recovery (Aux)' (page 22).

1. Connect the RedVision App to your GoBlock — tap on the Menu icon at the top left of the app to select/confirm that your GoBlock is selected from the Devices list.
2. Tap 'Recovery' in the Menu.
3. Select the type of Recovery you would like to initiate (Dock or Aux), then follow the in-app prompts.

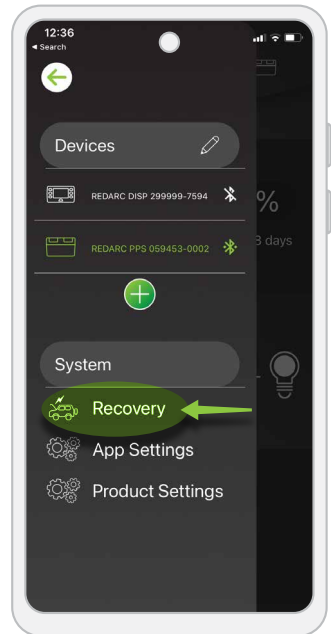

TRANSPORTING THE GoBlock

Carry Handles

The GoBlock's extendable carry handles allow it to be carried comfortably and safely.

⚠ CAUTION

- Lifting a heavy object can cause muscle strain or back injury. Use lifting aids if needed, and proper lifting techniques when moving the GoBlock.
- If you are not comfortable lifting the GoBlock on your own, get somebody to help you.
- Always carry the GoBlock by both handles to avoid muscle strain and to avoid damaging the handles and extension mechanisms.
- Two people are required to safely lift the GoBlock above shoulder height.

EXTEND THE CARRY HANDLES

Pull the handles firmly upwards.

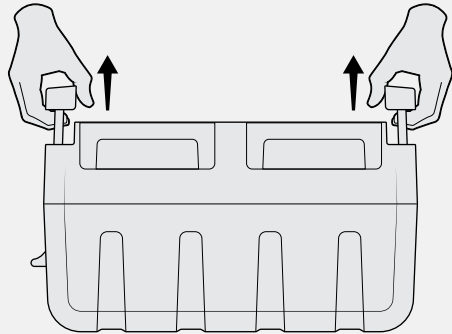

RETRACT THE CARRY HANDLES

⚠ CAUTION

Risk of pinch points.

With a flat palm, push firmly downwards to retract the carry handles.

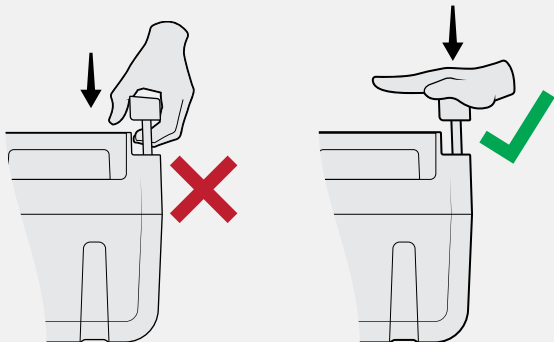

Safe Vehicle Transportation

⚠ WARNING

- An unsecured GoBlock can become dangerous in an accident or sudden stop. The GoBlock must be adequately restrained for safe transportation in a vehicle. Choose appropriate load restraint equipment, and ensure it's in good working order before every use.
- Load straps/restraint equipment must be replaced if they show any signs of wear or damage, or if the vehicle is in a minor or major accident.
- Do not leave sharp objects (e.g. drills, saws, knives, blades etc.) leaning on or nearby to the tie-down straps.
- The GoBlock must be installed behind (not in front) of the vehicle seats. Do not install the GoBlock in the vehicle interior area shared by occupants.
- Load straps and rings should each have a minimum 200 kg (440 lb) load capacity.

RECOMMENDED RESTRAINT METHODS

The following methods are recommended to restrain the GoBlock for safe transportation in a vehicle, however **it is the vehicle operators responsibility to ensure that the restraint method and equipment comply with local laws and standards.**

- Dock the GoBlock in the PowerDock (*sold separately* — refer to installation instructions supplied with the PowerDock to ensure the dock is correctly installed/anchored), and for instruction on how to dock the GoBlock.
- Restrain the GoBlock using tie-down straps attached to vehicle-mounted anchor points. Each strap and anchor point must be individually rated to a minimum of 200 kg (440 lb). See '[Restrain the GoBlock using Tie-Down Straps](#)' (page 31) for further information.

RESTRAIN THE GoBlock USING TIE-DOWN STRAPS

Additional anchor points may need to be installed in your vehicle if the standard vehicle anchor points are inadequately rated. To restrain the GoBlock with tie-down straps, use the following:

- 2 × Tie-down straps with a minimum load capacity of 200 kg (440 lb) each.
Nylon webbing straps are recommended — do not use elasticated straps.
- 4 × Anchor points with a minimum load capacity of 200 kg (440 lb) each.

Attach the tie-down straps centrally across the length and width of the GoBlock. Make sure that the straps are positioned over the Restraint Strap Guides. Anchor to the four anchor points and tighten the straps until the GoBlock can not move laterally when force is applied.

Secure the GoBlock with tie-down straps for safe vehicle transportation. The GoBlock can be oriented along or across the vehicle.

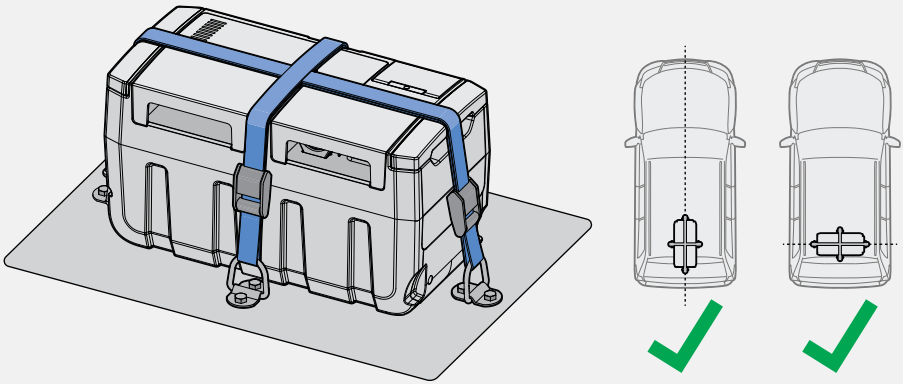

Position the tie-down straps centrally along the length and width of the GoBlock. Anchor point spacings must be equal to or less than the 'Max' dimensions shown (measured to the centre of the anchor point).

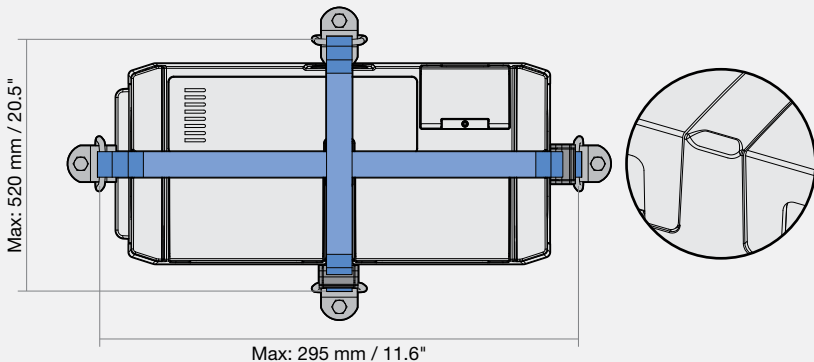

CARE AND MAINTENANCE

Care and Maintenance Advice

- Carefully inspect the unit before each trip to ensure it is in good condition. Do not use the GoBlock if you suspect that it has been damaged in any way.
- Always close the socket dust covers when input/output sockets are not in use.
- Keep the protective covers closed whenever possible.
- Do not subject connectors that are plugged in to excessive pulling or twisting. Excessive or repeated forces on the sockets may damage them or result in loose electrical connections.
- If sand, grit, or dirt accumulate on the body, handle extension rails, or in the compartments, wipe them clean with a damp cloth. Do not rinse/hose with water.
- Do not apply lubricants to the rails, as it could cause damage to the mechanism and body of the unit.
- Periodically check that the PowerDock Interface is clean and free of mud and grit before inserting into the dock. Wipe with a clean damp cloth.
- Do not use solvents to clean the GoBlock.
- Do not allow the GoBlock to come into contact with corrosive substances.
- Turn the Storage Isolation Switch to 'OFF' prior to prolonged periods of storage. See '[Storage Isolation Switch](#)' on [page 33](#) for more information.
- Do not fully charge or discharge the GoBlock prior to prolonged periods of storage. See '[Long-Term Storage](#)' on [page 33](#) for the recommended storage charge levels and detailed maintenance advice.
- In regular usage conditions, do not allow the GoBlock's charge level to remain below 10% for extended periods of time. Charge the GoBlock as soon as possible.

CABLE STRAIN RELIEF

The 50 A Anderson™ Output socket has an in-built cable strain relief that should be used to reduce strain on the Anderson™ socket and connector. Wrap the fastening strip around the connector body and secure tightly.

The Anderson™ output cable strain relief.

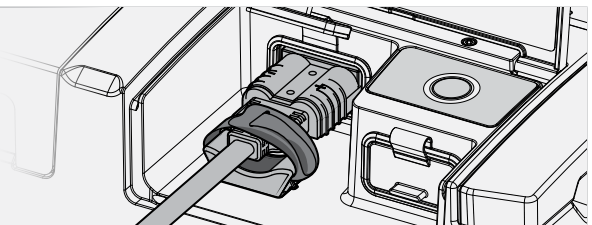

Long-Term Storage

STORAGE ISOLATION SWITCH

The GoBlock has a Storage Isolation Switch that disconnects the internal battery from the unit electronics. Note that it does NOT turn off the GoBlock inputs/outputs if there is another power source connected.

When to use the Storage Isolation Switch:

- It **should** be turned 'OFF' for long-term storage.
- It **must** be turned 'OFF' for freighting/shipping of the GoBlock.

NOTE: the Storage Isolation Switch is not intended for turning the GoBlock on/off during normal use. Instead, turn the unit on/off via the Control Button (page 12).

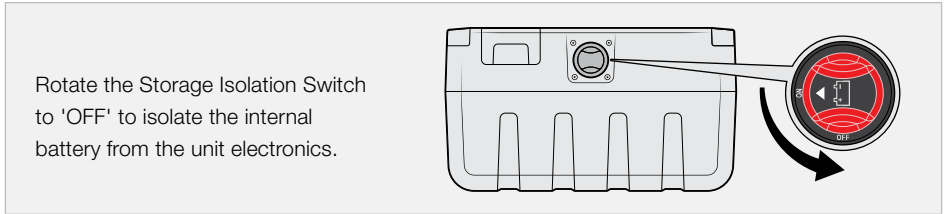

STORAGE BATTERY LEVEL

Do not fully charge or discharge the GoBlock prior to prolonged periods of storage. Ideally, the GoBlock should be stored with a charge level between 40% and 70%.

The GoBlock has a discharge rate of 1 to 3% per month (Storage Isolation Switch 'OFF'). Topping up the charge level periodically may be required to maintain the charge level within the recommended range.

INVERTERS

An inverter can be connected to the Anderson Output on the front of the GoBlock to charge/power higher-draw devices such as laptops.

The GoBlock is limited to 50 A from the Anderson Output. A 700 W inverter can be connected safely, however the GoBlock will not be able to supply the maximum 700 W. It is not recommended to connect an inverter larger than 700 W.

Check the power consumption of any loads you want to plug into your inverter and make sure your inverter is capable of supplying it. Many common household appliances draw higher power than the PPS/Inverter setup can supply.

Recommended Inverter Setup:

- REDARC 350 W Pure Sine Wave Inverter
- PPSKIT-001 GoBlock to Inverter Cable

Connecting the GoBlock to an inverter.

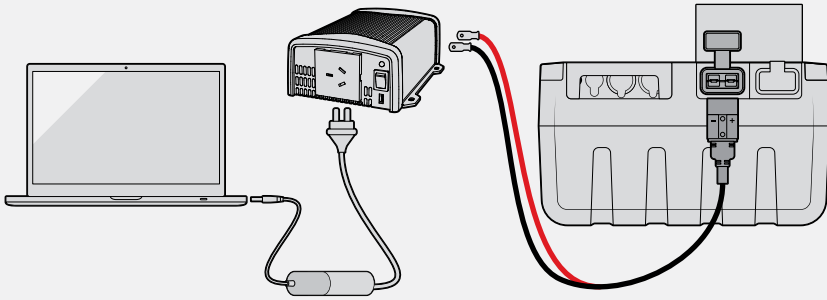

TROUBLESHOOTING

The GoBlock features sophisticated diagnostics to notify the user when the GoBlock is unable to function correctly.

Before contacting an authorised REDARC Distributor, try to resolve the cause of the Alert or Fault by following the recommended actions.

Faults

In rare cases, a Fault may occur indicating a fundamental problem with the GoBlock. Faults cannot be resolved, and all inputs/outputs will eventually cease operation.



In the event of a Fault, the Control Button LED illuminates solid red. Turn the Storage Isolation Switch to 'OFF' and then contact your local REDARC Distributor.

Alerts

Alerts allow you to continue using the GoBlock, however some functions may be limited or may not work at all until the Alert is resolved.



In the event of an Alert, the Control Button LED will flash red, and an Alert Code will be displayed by the Battery Level LEDs.

ALERT CODES

Each Alert has a corresponding LED on the Battery Level LEDs to indicate the cause of the Alert. Alerts can usually be resolved by following the steps described in '[Alert Code Identification and Resolution](#)' on page 36.

The REDARC RedVision® App also displays Alert Codes and a description that will help you to resolve Alerts. Installing the RedVision® App prior to a trip is recommended so that you can easily identify and resolve Alerts on-the-go.

Multiple Alerts can be displayed simultaneously by the Battery Level LEDs or the RedVision® App.



A single Fault Code displayed by the Battery Level LEDs.



Two separate Fault Codes displayed simultaneously by the Battery Level LEDs.

ALERT CODE IDENTIFICATION AND RESOLUTION



In the event of an Alert, the Control Button LED will flash red and an Alert Code will be displayed by the Battery Level LEDs.



Recovery — Internal Fault

Charge-back fault — something went wrong during Recovery.

Fault resolution:

1. If you are attempting to use the Recovery function via the auxiliary input while the GoBlock is docked in the PowerDock, remove the GoBlock from the dock and try to initiate Recovery again.
-



Recovery — No Battery Connected

Output battery can not be detected.

1. Check that a vehicle start battery is connected to the GoBlock or PowerDock.
 2. Check for loose connections to the vehicle start battery.
-



Over Temperature

GoBlock is too hot — unit temperature is above 45°C / 113°F (when charging), or 60°C / 140°F (when discharging).

1. Immediately move the GoBlock to a cooler/shaded location. When the unit has returned to operating temperature, the fault will resolve.

Over Temperature Alarm

Note that if the GoBlock exceeds 60°C / 140°F an alarm tone will sound every 10 seconds. Immediately move the GoBlock to a cooler/shaded location. The alarm can then be silenced for 10 minutes by pressing the Control Button. If, after 10 minutes, the GoBlock temperature still exceeds 60°C / 140°F then the alarm tone will recommence.

If the GoBlock exceeds 70°C / 140°F, an alarm tone will sound every 10 seconds, and cannot be silenced until the unit temperature is below 70°C / 140°F.

NOTICE: Failure to resolve an Over Temperature alarm may result in damage to the GoBlock's internal battery.



Under Temperature

GoBlock is too cold — temperature is below 0°C / 32°F (when charging), or -20°C / -4°F (when discharging).

1. Move the GoBlock to a warmer location. When the unit has returned to operating temperature, the fault will resolve.
-



Input Over Voltage

The Alternator or Trickle-Charge Input is too high voltage, or the total voltage rating of connected solar panels is too high.

1. Check the voltage rating of auxiliary products and make sure that they do not exceed the limits of each input. See 'Inputs' listed under 'Electrical Specifications' (page 41).
2. Unplug overrated items one-by-one until the fault resolves.
3. If connected, check that solar panels are suitably rated for use with the GoBlock.
4. If connected, disconnect solar panels one-by-one until the fault resolves.



Input Reverse Polarity Detected

Connected auxiliary items may be wired incorrectly (i.e. wired 'backwards').

1. Check for reverse polarity in the wiring of connected loads by disconnecting them one at a time until the fault resolves.
2. Discontinue use of any accessories that cause an 'Input Reverse Polarity Detected' alert.



Output Overcurrent

The combined current rating of connected loads exceeds 50 A, i.e. There may be too many loads plugged in.

Priority is given to the Fridge Socket.

1. Disconnect one or more of the loads until the fault resolves.



Battery Level Critically Low (< 5%)

The GoBlock's Battery level is less than 5%.

1. Charge the GoBlock.

General Troubleshooting

If you experience any of the listed problems, follow the recommended actions in order until the problem is resolved — all steps may not be needed to resolve the problem.

If the problem persists after completing all of the recommended actions, contact REDARC directly, or your local REDARC Distributor.

The Control Button LED is illuminated solid red

There is a Fault. Turn the Storage Isolation Switch to 'OFF' and then contact your local REDARC Distributor. See [page 35](#) for more information about Faults.

The GoBlock will not power on, even after pressing the Control Button

1. Check that the Storage Isolation Switch is turned to 'ON' ([page 33](#)).
2. The GoBlock may be completely discharged (flat). If needed, charge the GoBlock.
3. Disconnect all loads/inputs, then turn the Storage Isolation Switch 'OFF' ([page 33](#)). Wait for 10 seconds and then turn the switch back 'ON', then try turning the GoBlock on again by pressing the Control Button.

The Protective Covers have come off

The protective covers are removable. If they come off, they can be easily reattached.

Align the plastic hinge clips with the metal hinge pins in the GoBlock body and press down firmly until the Protective Cover snaps into position.

The Control Button is flashing red and one or more Battery Level LEDs are illuminated

There is a Alert. Refer to [page 35](#) for more detailed information and ways to identify and resolve individual Alerts.

The Carry Handles will not retract smoothly, or won't move at all

1. Make sure that there are no obstructions underneath the handles that are preventing them from retracting.
2. Make sure the handle rails are clean and free of grit and dust. Wipe them with a clean damp cloth.

NOTICE: do not apply lubricants to the handle rails, as it could cause damage to the mechanism and body of the unit.

The GoBlock stops charging before the Battery Level LEDs reach 100%

The internal battery cells may not be equalised. Completely discharge the battery to flat, then leave on charge for 24 hours.

GoBlock will not charge

1. Check that the Storage Isolation Switch is turned to 'ON' (page 33).
2. Check that the GoBlock is not already completely charged.
3. Check that there is not an Over/Under Temperature Alert. See 'Alert Codes' (page 35).
4. Check power is available (one or many of the below reasons, depending on your use case)
 - a. Confirm that the AC wall outlet you are connected to is switched on, and is functioning correctly (try connecting a different appliance to the wall outlet).
 - b. Check for any loose connections between the charging source and the GoBlock.
 - c. Check if an external wiring fuse has blown.
 - d. Check that solar panels are not shaded.
 - e. Check that the Vehicle Ignition is turned on.
5. Turn the GoBlock Off via the Control Button, wait for approximately 10 seconds and then turn it On again. See 'Turn GoBlock On and Off' (page 12).

GoBlock will not connect to the RedVision® App

1. Make sure you are in close range to the GoBlock (within approximately 5 metres / 16'5").
2. Check that Bluetooth® is enabled on your device.
3. Remove the GoBlock from the devices list in the RedVision® App and also from the Bluetooth® devices list in your smartphone settings.
4. Make sure there are no other Bluetooth® devices connected to the GoBlock (the Control Button LED should be off) and then delete all pairings. See 'Delete All Pairings' (page 25).
5. Turn the GoBlock Off via the Control Button, wait for approximately 10 seconds and then turn it On again. See 'Turn GoBlock On and Off' (page 12).
6. Disconnect all loads/inputs, and remove the GoBlock from the PowerDock (if docked). Turn the GoBlock Off via the Control Button, wait for approximately 10 seconds and then turn it On again.
7. Turn your smartphone off and then on again.
8. Re-pair the GoBlock and smartphone. See 'Pair to the GoBlock Via Bluetooth' (page 24).

The Bluetooth® connection keeps dropping out

1. Make sure there are no obstructions between the GoBlock and your device (such as a vehicle or your body) that may prevent a good Bluetooth® connection.
2. Move the paired device closer to the GoBlock.
3. Remove the GoBlock from the devices list in the RedVision® App and also from the Bluetooth® devices list in your smartphone settings.
4. Make sure there are no other Bluetooth® devices connected to the GoBlock (the Control Button LED should be off) and then delete all pairings. See 'Delete All Pairings' (page 25).

TECHNICAL SPECIFICATIONS

Battery Specifications

	PPS12050	PPS12100
Battery capacity	50 Ah (640 Wh)	100 Ah (1280 Wh)
Nominal Voltage	12.0 – 15.8 V	
Battery chemistry	LiFePO ₄ (lithium iron phosphate)	
Self discharge rate	Isolated: 1 to 3% per month Sleep: ≈ 2 months Off: ≈ 5 months	1 to 3% per month ≈ 4 months ≈ 10 months
Cycle life	2000 cycles (capacity retention ≥ 80%)	

Physical Specifications

	PPS12050	PPS12100
Weight	15 kg / 33.07 lb	19 kg / 41.89 lb
Dimensions	196 × 230 × 425 mm / 7.72" × 9.06" × 16.73"	

Thermal Specifications

Operating Temperature Range

Discharging	-20°C to 60°C / -4°F to 140°F
Charging	0°C to 45°C / 32°F to 113°F
Operating	-40°C to 65°C / -40°F to 149°F

Over Temp Shut-down/Derate

Discharging	60°C / 140°F
Charging	45°C / 113°F

Electrical Specifications

INPUTS

Trickle-Charge Input (Barrel Jack)

Maximum Current	7.5 A
Nominal Voltage	13.5 V
Efficiency	> 90%
Protection	Overvoltage at 15.8 V

PowerDock Vehicle Input

Maximum Current	50 A
Operating Voltage Range	9 to 32 V
Turn On/Off Threshold	12.7 – 15.8 V (in 12 V installation, ignition not connected) 12.0 – 15.8 V (in 12 V installation, ignition connected) 25.4 – 32.0 V (in 24 V installation, ignition not connected) 24.0 – 32.0 V (in 24 V installation, ignition connected)
Power Rating	625 W
Efficiency	> 96 %
Protection	Overcurrent at 55 A, Overvoltage at 36 V

PowerDock Solar Input

Maximum Current	50 A
Operating Voltage Range	9 to 32 V
Turn On Threshold	9 V
Power Rating	800 W
Efficiency	> 93 %
Protection	Overcurrent at 55 A, Overvoltage at 32 V

Auxiliary Anderson™ Input

Maximum Current	50 A
Operating Voltage Range	9 to 32 V
Power Rating	800 W
Efficiency	> 93 %
Protection	Overcurrent at 55 A, Overvoltage at 32 V

OUTPUTS

Total Output Current Limit	50 A		
	Current rating	Nominal voltage	Protection (nominal/typical)
Accessory Socket	10 A	13.5 V	
Merit Socket	15 A	13.5 V	All outputs are overcurrent protected with automatic resettable electronic fuses
Fridge Socket	15 A	13.5 V	
USB Type A Outputs (x 4)	2.4 A (each)	5 V	
Anderson™ Output	50 A	13.5 V	

Compliance and Standards

Safety	AC Charger – RCM Battery tested to UN38.3 and IEC 62133-2
EMC	RCM



WARRANTY

LIMITED WARRANTY

For full warranty terms and conditions, visit the Warranty page of the REDARC website. Refer to the web address and contact details applicable to your region.

Australia, New Zealand & Europe

www.redarc.com.au/warranty

REDARC Electronics Pty Ltd
23 Brodie Road (North),
Lonsdale SA 5160
Australia

Australia +61 8 8322 4848
New Zealand +64 9 222 1024
UK & Europe +44 (0)20 3930 8109

North America

www.redarcelectronics.com/warranty

REDARC Corporation
c/o Shallco, Inc.
308 Component Dr.
Smithfield, NC 27577
USA

USA +1 (704) 247 5150
Canada +1 (604) 260 5512
Mexico +52 (558) 526 2898

ADDITIONAL INFORMATION

Safe Disposal of the Product

LiFePO₄ batteries must be disposed of in accordance with local laws. Never dispose of a LiFePO₄ in household or general waste.

⚠ WARNING

- Do not incinerate or dispose of in fire.
- LiFePO₄ batteries must not be transported by air under any circumstances.
- Do not attempt to remove the internal batteries from the unit for disposal.

Contact your local battery recycling facility for direction on the safe disposal of the GoBlock.

GoBlock Shipping Advice

LiFePO₄ batteries are categorised as dangerous goods and must only be shipped/freighted using the prescribed methods.

Scan the QR code for GoBlock shipping advice for your region.

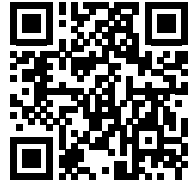

Checking the Product Serial Number

The Product Serial Number is located on the Main Unit and on the product packaging.

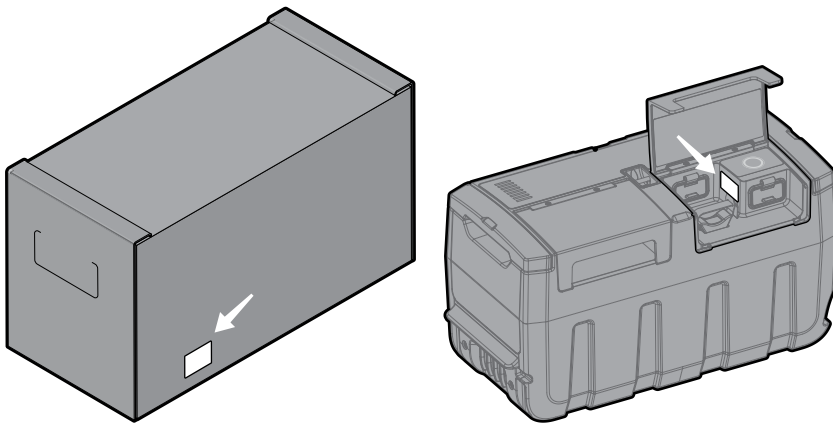

REDARC Electronics Pty Ltd

ABN 77 136 785 092

REDARC Electronics Pty Ltd
23 Brodie Road (North),
Lonsdale SA 5160
Australia

PATENTS

Patents apply.

Australia

Australian Design Registration:
202013504 (GoBlock)
202013505 (PowerDock)

U.S.A

US Design Patent Application:
29/763,612 (GoBlock)
29/763,615 (PowerDock)

Canada

Canadian Design Application:
200238 (GoBlock)
200237 (PowerDock)

Mexico

Mexican Design Application:
MX/F/2021/000022 (GoBlock)
MX/F/2021/000021 (PowerDock)

Product configuration and technical specifications are subject to change without notice.

Copyright © 2021 REDARC Electronics Pty Ltd. All rights reserved.

REDARC®, GoBlock®, PowerDock™, RedVision® and THE POWER OF REDARC® are trademarks of REDARC Electronics Pty Ltd.

The Bluetooth® word mark and logos are registered trademarks owned by Bluetooth SIG, Inc. and any use of such marks by REDARC is under license. Other trademarks and trade names are those of their respective owners.

Anderson™ and Anderson Power Products® are trademarks of Anderson Power Products, Inc.

THE POWER OF
REDARC®

CONTACT

Tech Support 1300 REDARC (1300-733-272)

Australia +61 8 8322 4848

New Zealand +64 9 222 1024

UK & Europe +44 (0)20 3930 8109

redarc.com.au

USA +1 (704) 247-5150

Canada +1 (604) 260-5512

Mexico +52 (558) 526-2898

redarcelectronics.com

THE POWER OF

REDARC[®]

